



37FSB

BALANCED FULLY SPLIT SEAL

Applications

The Type 37FSB fully split seals contribute to significantly reduced maintenance on larger, difficult-to-seal equipment. They are recommended for use on heavy duty, packed equipment that previously could not accommodate mechanical seals because of severe vibration, difficulty to disassemble, and similar problems. Type 37FSB seals are outside mounted and can be used on vertical and horizontal applications.

- For use in larger rotating shaft equipment — mixers, agitators, pumps.
- For use in pulp and paper pumps, food and beverage mixers, power generation pumps, pharmaceutical slow-running mixers, wastewater treatment raw sewage pumps and mining slurry pumps.
- Type 37FSB seals are repairable easily and quickly on-site or at any John Crane Seal Rebuilding Center, with genuine John Crane factory-specified replacement parts. This unique feature minimizes replacement costs and production downtime.

Operating Conditions\*

- Temperatures: +82°C/+180°F maximum
- Pressures: 14 bar g/200 psig maximum
- Speeds: 1800 rpm maximum

\*For other operating conditions, consult John Crane Engineering

37FSB

INCH RANGE

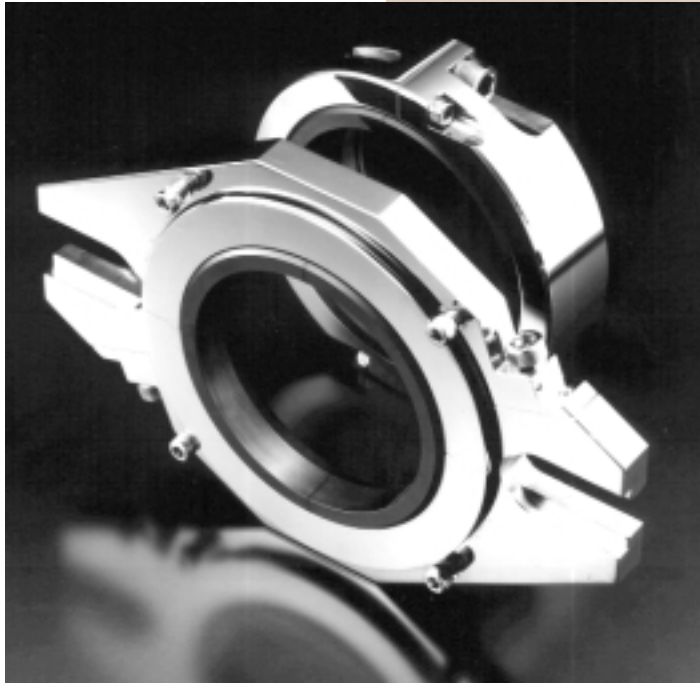



37FSB

## BALANCED FULLY SPLIT SEAL

### Design Features

---

#### Easy Installation

Fewer parts and simple design allow for easy installation. Seal can be readily mounted on worn shafts and on out-of-square stuffing boxes. No modification of equipment is needed.

#### Solves Movement Problems

Type 37FSB seal solves vibration problems that prohibit use of other seal designs. Unique John Crane-developed compression ring provides extreme flexibility. Shaft deflections, angular misalignments, and runouts are "tracked" by the seal without diminishing performance.

#### Self-Aligning

Rotating assembly of this new generation split seal, self-aligns square with the shaft for true running under varying conditions.

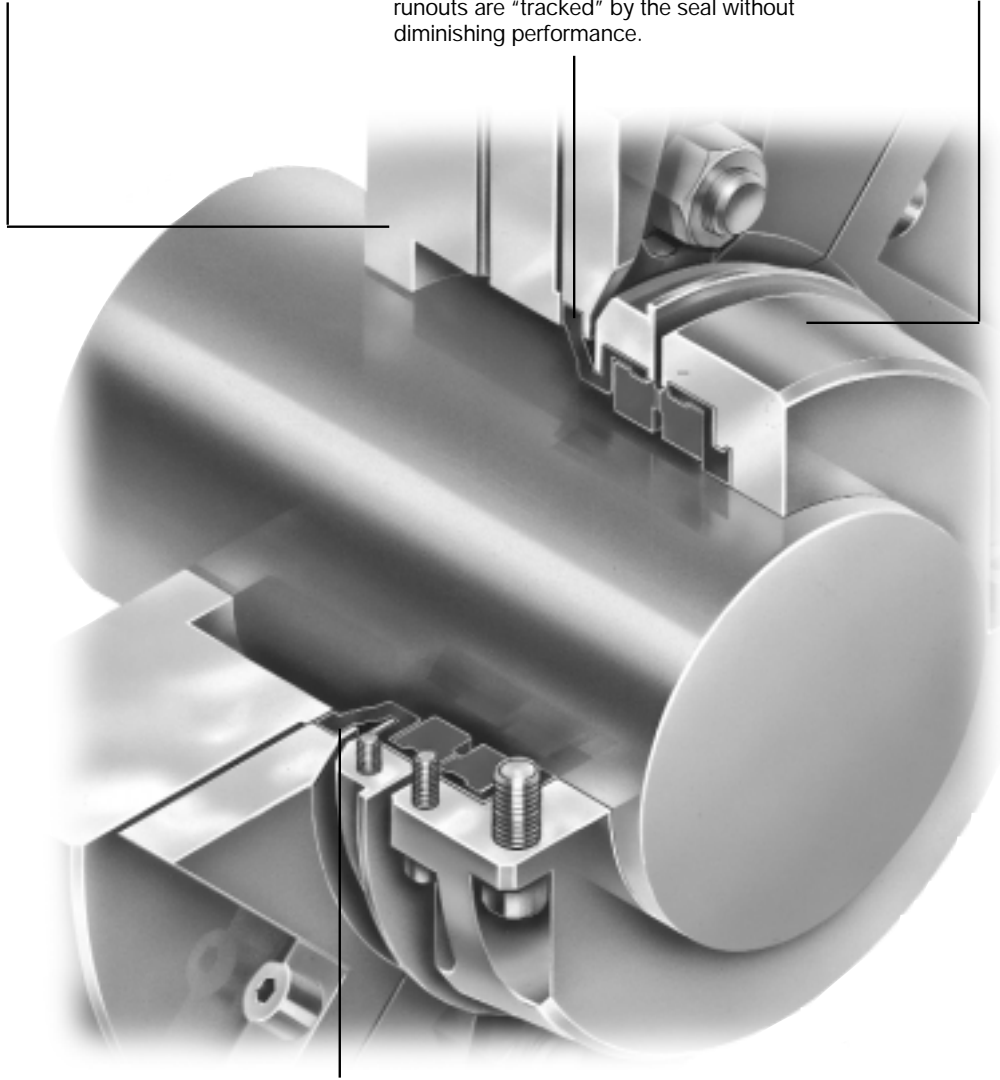

#### Non-Clogging

Non-pusher design provides extreme flexibility in operation with no hang-ups or clogging. Design eliminates springs and O-rings.



37FSB

**BALANCED FULLY SPLIT SEAL**

**Type 37FSB Typical Arrangement/Dimensional Data**

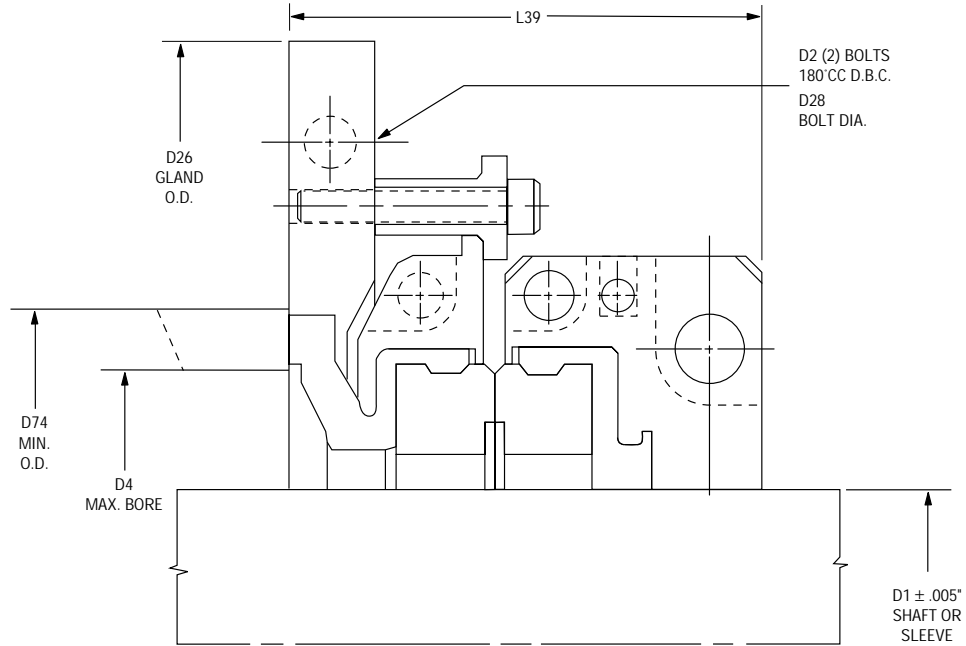

**Chart 1. Type 37FSB Dimensional Data (Inches)**

Shaft/ Sleeve Size D1	L39						
	D2	D4	D26	D28	D74	SIC/SIC*	CAR/SIC **
3.437-3.811	8.250-10.750	5.375	11.750	.750	6.182	3.42	3.48
3.812-4.186	8.625-11.125	5.750	12.125	.750	6.557	3.42	3.48
4.187-4.561	9.000-11.500	6.125	12.500	.750	6.932	3.42	3.48
4.562-4.936	9.375-11.875	6.500	12.875	.750	7.307	3.42	3.48
4.937-5.311	9.750-12.250	6.875	13.250	.750	7.682	3.42	3.48
5.312-5.686	10.125-12.625	7.250	13.625	.750	8.057	3.42	3.48
5.687-6.061	10.500-13.000	7.625	14.000	.750	8.432	3.42	3.48
6.062-6.436	10.875-13.375	8.000	14.375	1.000	8.807	3.63	3.69
6.437-6.811	11.250-13.750	8.375	14.750	1.000	9.182	3.63	3.69
6.812-7.186	11.625-14.125	8.750	15.125	1.000	9.557	3.63	3.69
7.187-7.561	12.000-14.500	9.125	15.500	1.000	9.932	3.63	3.69
7.562-7.936	12.375-14.875	9.500	15.875	1.000	10.307	3.63	3.69
7.937-8.311	12.750-15.250	9.875	16.250	1.000	10.682	3.63	3.69
8.312-8.686	13.125-15.625	10.250	16.625	1.000	11.057	3.63	3.69
8.687-9.061	13.500-16.000	10.625	17.000	1.000	11.432	3.63	3.69
9.062-9.436	13.875-16.375	11.000	17.375	1.000	11.807	3.63	3.69
9.437-9.811	14.250-16.750	11.375	17.750	1.000	12.182	3.63	3.69
9.812-10.187	14.625-17.125	11.750	18.125	1.000	12.557	3.63	3.69

\* SIC/SIC = Silicon Carbide vs. Silicon Carbide

\*\* CAR/SIC = Carbon vs. Silicon Carbide



37FSB

## BALANCED FULLY SPLIT SEAL

### Flexibility Specifications

**1. Seal chamber dimensions and finishes:**

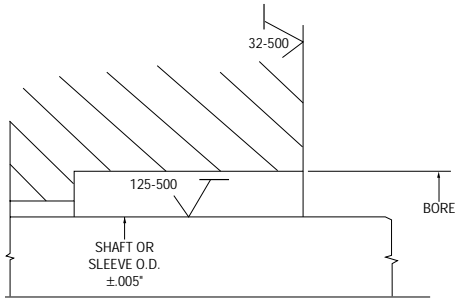

**2. Axial end play**

Seal sizes 3.625" to 10.000" -0.060" T.I.R. max.

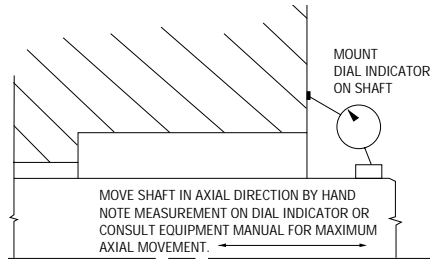

**3. Squareness of seal chamber face to shaft**  
Carbon vs. Silicon = 0.050" T.I.R. max  
Silicon vs. Silicon = 0.100" T.I.R. max

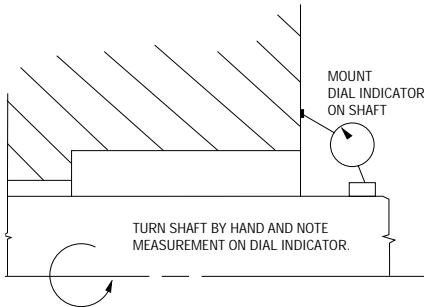

**4. Shaft runout (0.020" T.I.R. max).**

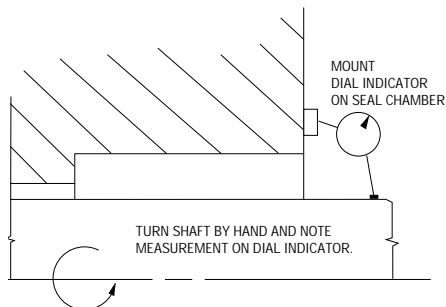

**5. Stuffing box face waviness (0.030" T.I.R. max).**

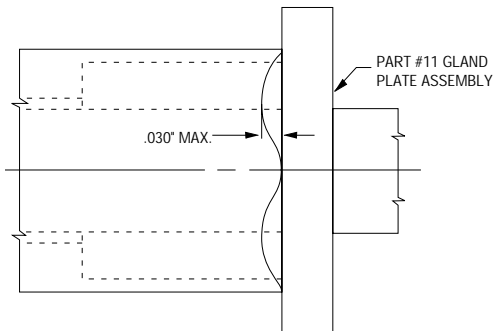

**6. Radial shaft movement (0.125" T.I.R. max)**

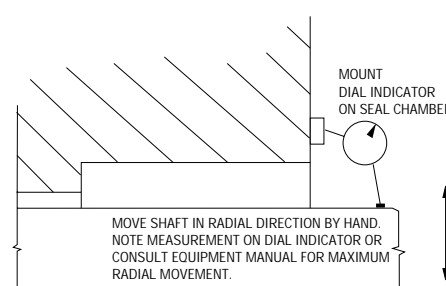



37FSB

## BALANCED FULLY SPLIT SEAL

Chart 2. Pressure/Velocity (PV) Limits

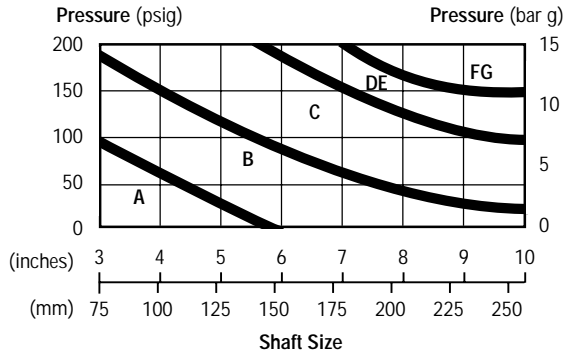

- A. Silicon Carbide vs. Silicon Carbide (Similar) 1800 rpm
- B. Silicon Carbide vs. Silicon Carbide (Similar) 1200 rpm
- C. Silicon Carbide vs. Silicon Carbide (Similar) 800 rpm
- D. Silicon Carbide vs. Silicon Carbide (Dissimilar) 1800 rpm
- E. Carbon vs. Silicon Carbide 1800 rpm
- F. Silicon Carbide vs. Silicon Carbide (Dissimilar) 1200 rpm
- G. Carbon vs. Silicon Carbide 1200 rpm

Chart 3. Materials of Construction

Seal Component Materials		Secondary Sealing Element	Primary Ring	Hardware Clamp Ring, Drive Ring, Gland Plate, Fasteners	Mating Ring	Mechanical Loading Device Spring
Materials	Standard	Ethylene Propylene	Silicon Carbide Coarse Grain	316 Stainless Steel	Silicon Carbide Coarse Grain	
		Buna-N	Carbon	Monel (Bolts only)		
	Options	Fluoroelastomer				
		Aflas*				

\* Aflas is a registered trademark of Asahi Glass Co., Ltd.

Chart 4. Criteria for Installation

Shaft/Sleeve	Limits
Surface Finish	125-500 Ra
Ovality/Out of Roundness (Shaft)	0.13 mm/0.005"
End Play/ Axial Float Allowance	±0.76 mm/0.030"
Axial Runout /Out of Squareness	1.27 mm/0.050" TIR    Carbon vs. Silicon Carbide 2.54 mm/0.100" TIR    Silicon Carbide vs. Silicon Carbide



37FSB

# BALANCED FULLY SPLIT SEAL

## Application Information

The Type 37FSB Seal is custom-tailored to the application required. Applications must be reviewed by John Crane Engineering. The following data is necessary to evaluate the proposed application.

Customer's Name: \_\_\_\_\_ Location: \_\_\_\_\_  
JC Salesman: \_\_\_\_\_ Phone # \_\_\_\_\_

### 1. Equipment:

Type: \_\_\_\_\_ Manufacturer: \_\_\_\_\_  
Model: \_\_\_\_\_ Installation: Horizontal \_\_\_\_\_ Vertical: \_\_\_\_\_  
If Vertical, Top or Bottom Entering: \_\_\_\_\_

### 2. Application:

Process Fluid: \_\_\_\_\_ Specific Gravity: \_\_\_\_\_  
Viscosity: \_\_\_\_\_ Vapor Pressure: \_\_\_\_\_  
Injection Fluid: \_\_\_\_\_ Available Pressure: \_\_\_\_\_  
Max. Allowable Pressure: \_\_\_\_\_ Max. Allowable Flow Rate: \_\_\_\_\_

### 3. Operation:

Speed: \_\_\_\_\_ Temperature: \_\_\_\_\_ Stuffing Box Pressure: \_\_\_\_\_  
Suction Pressure: \_\_\_\_\_ Discharge Pressure: \_\_\_\_\_

### 4. Dimensions:

Sleeve O.D. (A) (if applicable): \_\_\_\_\_ Shaft/Sleeve Surface Finish: \_\_\_\_\_  
Sleeve Extension (B) (if applicable): \_\_\_\_\_ Shaft O.D. (C): \_\_\_\_\_  
Stuffing Box Bore (D): \_\_\_\_\_ Stuffing Box O.D. (E): \_\_\_\_\_  
Bolt Circle Diameter (F): \_\_\_\_\_ Number & Size of Bolts (G, H): \_\_\_\_\_  
Type of Bolts: (Circle Appropriate): Bolt Extension (I): \_\_\_\_\_  
Nearest Obstruction (J): \_\_\_\_\_  
Swing Bolts:   
Studs:  Removable? Yes  No   
Tapped Holes:

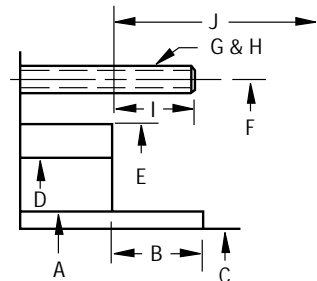

**John Crane Mechanical Seals**  
Engineered Sealing Systems

**North America**  
Morton Grove, Illinois USA

Tel: 1-847-967-2400  
Fax: 1-847-967-3915  
1-800-SEALING

**Latin America**  
Mexico City, Mexico

Tel: 52-5-567-4511  
Fax: 52-5-587-2342

**Europe, Middle East, Africa**  
Slough, UK

Tel: 44-1753-224000  
Fax: 44-1753-224224

**Asia Pacific**  
Singapore

Tel: 65-222-9161  
Fax: 65-223-5035

If the products featured will be used in a potentially dangerous and/or hazardous process, your John Crane representative should be consulted prior to their selection and use. In the interest of continuous development, John Crane Companies reserve the right to alter designs and specifications without prior notice.